



Rewarding Learning

General Certificate of Secondary Education  
2022

Centre Number

--	--	--	--	--

Candidate Number

--	--	--	--

# Physics

Unit 3: Practical Skills

Booklet A

Higher Tier



\*GPY33\*

[GPY33]

### TIME

2 hours.

### INSTRUCTIONS TO CANDIDATES

Write your Centre Number and Candidate Number in the spaces provided at the top of this page.

Write your answers in the spaces provided in this question paper.

Answer **all** questions.

### INFORMATION FOR CANDIDATES

The total mark for this paper is **30**.

Figures in brackets printed down the right-hand side of pages indicate the marks awarded to each question or part question.

Follow all health and safety instructions.

You may use a ruler, protractor and calculator if required.

The apparatus and materials required to complete the task(s) are provided.

### FOR TEACHER USE ONLY

In Experiment 2 it is assumed that the candidate was given help to complete the circuit. If this is **not** the case please tick the box below.

No help was given

Examiner's use only	Marks
Experiment 1	
Experiment 2	
<b>Total Marks</b>	





You must work alone for the remainder of Experiment 1.

### Analysis of data

#### Step 4

Calculate the mass of each volume of water.

Remember, the mass values in **Table 1** include the mass of the small empty beaker that you measured earlier.

Record each measurement in column 2 of **Table 2** below, to which you should add a heading and appropriate unit. [2]

**Table 2**

Column 1	Column 2	Column 3
Volume of water/cm <sup>3</sup>		
50		
100		
150		
200		
250		

Examiner Only

Marks

Remark

Step 5

Calculate the density of water **to one decimal place** for each set of values in **Table 2**.

Use the equation below to calculate the density.

$$\text{Density} = \frac{\text{Mass}}{\text{Volume}}$$

Record the density values in column 3 of the table opposite. Add a column heading with appropriate unit to column 3. [3]

**Use the space below for your calculations.**

Examiner Only	
Marks	Remark

### Interpretation of the data

- 1 Use the values of mass and volume from **Table 2** to plot a graph on the grid below.  
Use the vertical axis for the mass and the horizontal axis for the volume.  
Use  $\odot$  or  $\times$  to clearly show your points.  
Draw a straight line of best fit through the points.  
The straight line should pass through the origin (0,0) which has been plotted for you.

[3]

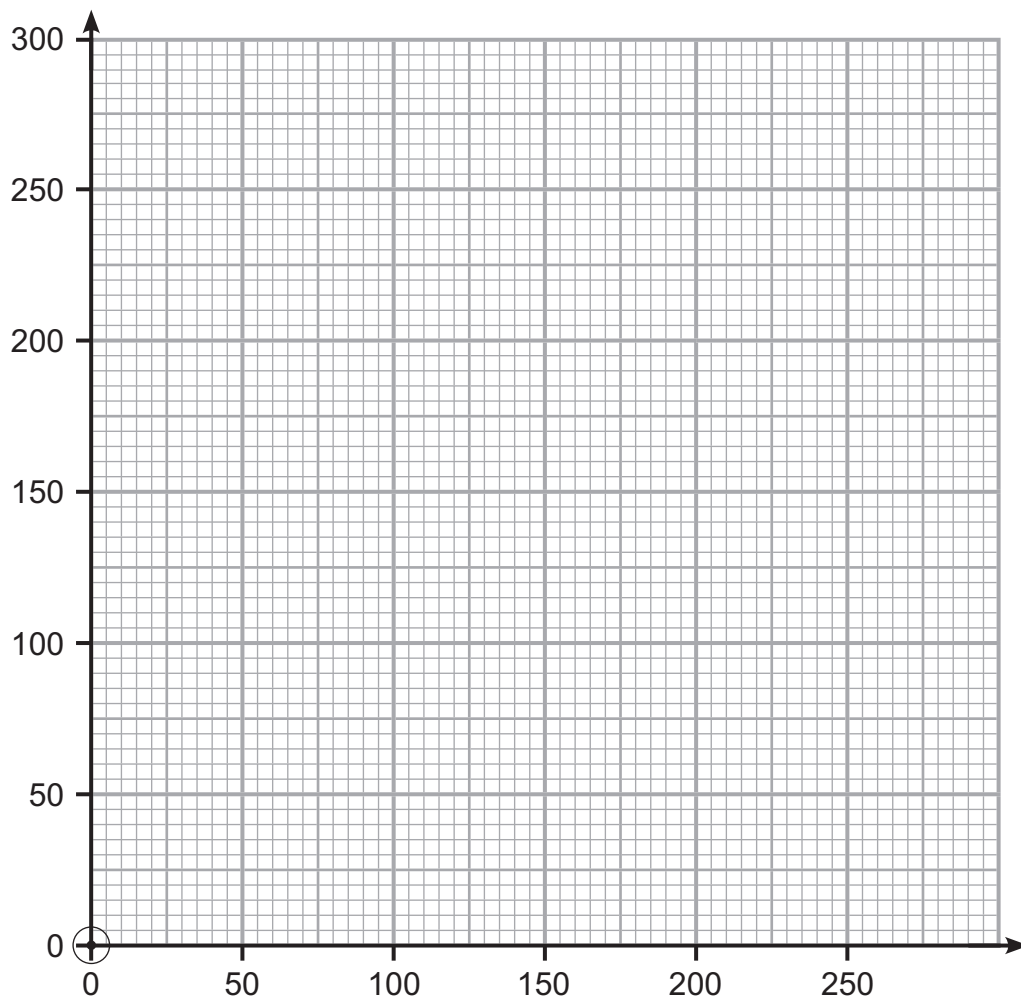

Examiner Only	
Marks	Remark
○	○

2 Name the mathematical relationship between the mass of water and its volume shown by this graph.

\_\_\_\_\_ [1]

3 Calculate the gradient of the graph and state its unit.

Gradient = \_\_\_\_\_

Unit = \_\_\_\_\_ [2]

Examiner Only	
Marks	Remark
○	○

## Experiment 2 Strength of an electromagnet

### Introduction

A coil is wrapped around an iron nail. This arrangement of coil and iron nail forms an electromagnet. The strength of the electromagnet depends on the current flowing through the coil.

### Aims

The aim of this experiment is to determine the relationship between the strength of the electromagnet and the current flowing through the coil. The strength of the electromagnet will be measured by how many paper clips the electromagnet can lift.

### Apparatus

The electromagnet is held in place on a stand as shown in the diagram below.

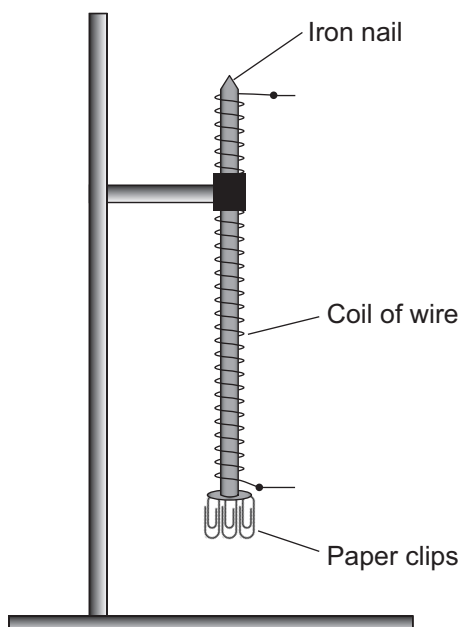

During steps 1 and 2, you can carry out the practical activity individually or in a group of two or three.

### Procedure

#### Step 1

Complete the circuit described in the circuit diagram below by adding the variable resistor to the correct place.

**Before proceeding, have the teacher check your circuit.**

[2]

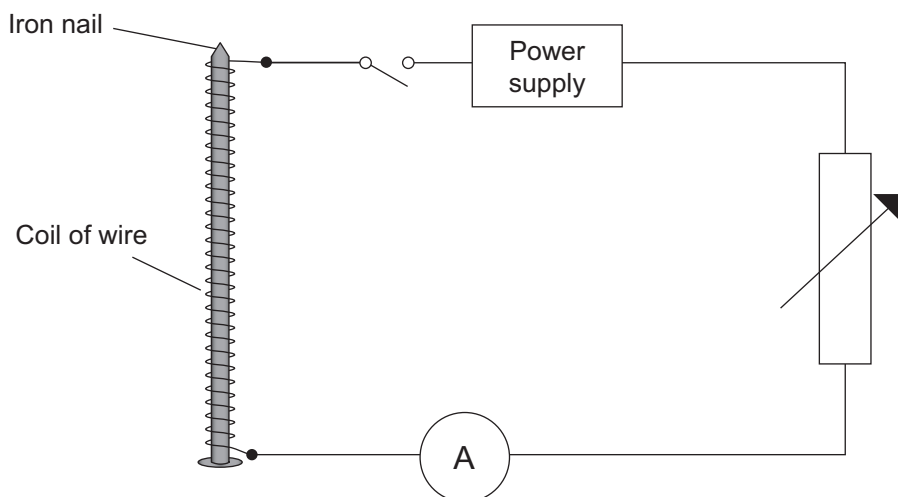

If you cannot set up the circuit, raise your hand and tell the teacher, who will then assist you.

You will not then be credited with the two marks for this part of the practical assessment.

Now raise your hand and ask permission to switch on the power supply. Do NOT proceed until permission has been given to you.

Switch on the Power Supply Unit, but do NOT adjust any voltage setting on the power supply unless the teacher gives you permission to do so.

Examiner Only	
Marks	Remark
<input type="text"/>	<input type="text"/>

## Step 2

Close the switch to turn the current on and check that you can obtain currents up to 1.5A when you adjust the variable resistor. Now turn the current off by opening the switch.

## Trial 1

Switch on the current and adjust the variable resistor to give a current of 0.5A.

Attach as many paper clips as you can to the **bottom** of the iron nail, as shown in the diagram. Record the number of paper clips in the column headed Trial 1 in **Table 3** opposite.

Adjust the current to a value of 1.0A and add more paper clips to the bottom of the iron nail. Record the **total** number of paper clips in the column headed Trial 1 in the table opposite.

Repeat this process by increasing the current to 1.5A. Record the **total** number of paper clips in the column headed Trial 1 in the table opposite.

When you have completed Trial 1, switch off the current after you have recorded the total number of paper clips, and remove all the paper clips from the nail.

[2]

## Trial 2

Repeat all the measurements you made in Trial 1 and record your results in the column headed Trial 2 in the table opposite.

When you have finished, switch off the power supply.

[2]

Examiner Only	
Marks	Remark

**Table 3**

	Maximum number of paper clips held by electromagnet	
Current/A	Trial 1	Trial 2
0.0	0	0
0.5		
1.0		
1.5		

**When you have taken all the measurements, or when the teacher tells you that 30 minutes are over, stop using the apparatus.**

**To complete the remainder of the assessment, you must work alone.**

**The teacher will direct you to a place to do this.**

You must work alone for the remainder of Experiment 2.

### Analysis of data

#### Step 3

For each current, use the values from **Table 3** to calculate the average number of clips **to the nearest whole number**. Write these values in **Table 4** below. [2]

**Table 4**

Current/A	Average number of paper clips held by the electromagnet
0.0	0
0.5	
1.0	
1.5	

Examiner Only

Marks

Remark

### Interpretation of the data

- 1 On the grid below, plot a graph of the average number of paper clips held by the electromagnet against the current. Plot all the points clearly and carefully using  $\odot$  or  $\times$  to show the points. Draw the straight line of best fit.

[3]

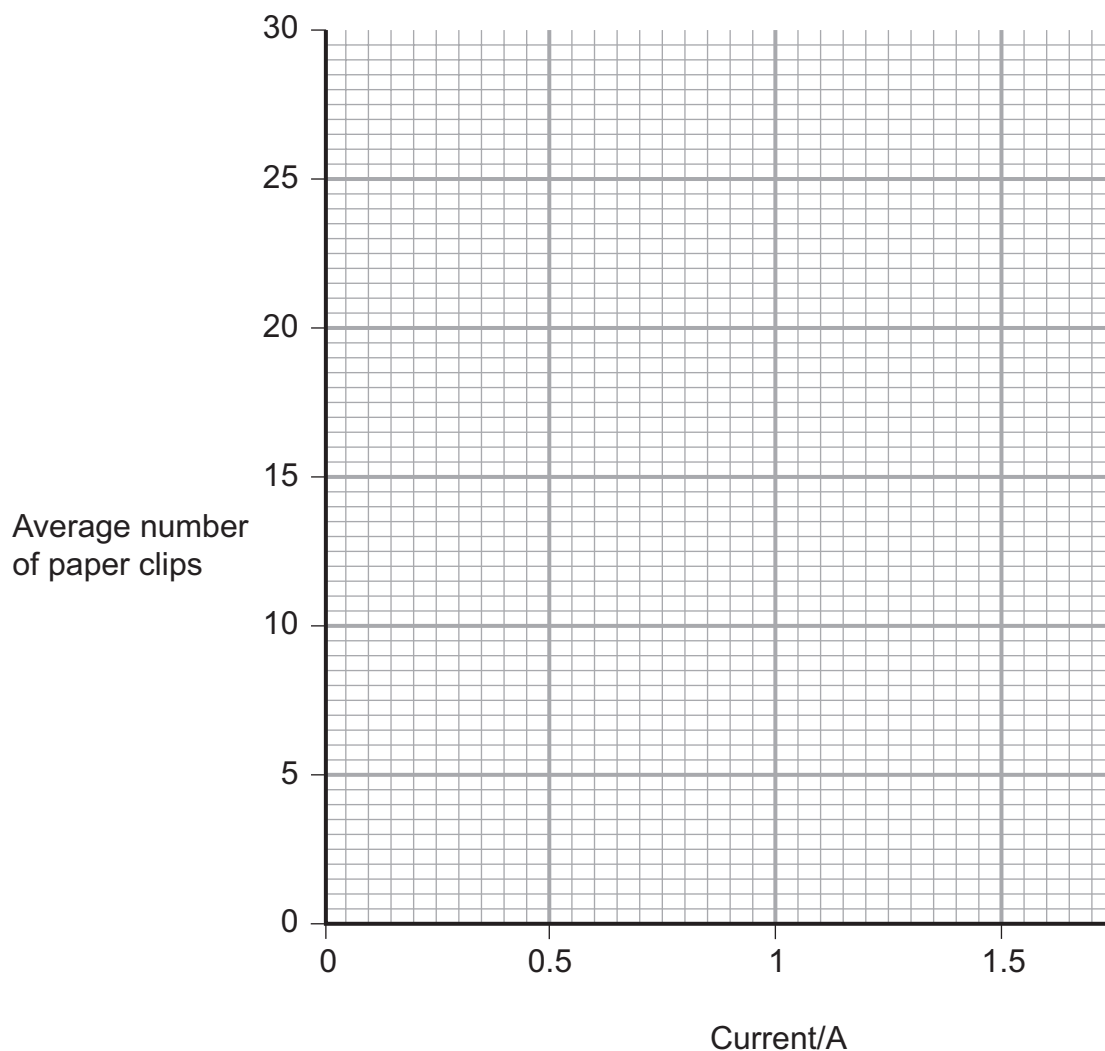

Examiner Only	
Marks	Remark
<input type="text"/>	<input type="text"/>

- 2 Which one of the following statements best describes what you have found? Tick the appropriate box below. Tick (✓) only **one** box.

The average number of paper clips held by the electromagnet decreases as the current increases	
The average number of paper clips held by the electromagnet increases as the current increases	
The average number of paper clips held by the electromagnet does not depend on the current	

[1]

- 3 In the experiment that you carried out, name the independent variable.

\_\_\_\_\_ [1]

- 4 In the experiment that you carried out, name the dependent variable.

\_\_\_\_\_ [1]

- 5 In the experiment that you carried out, name one control variable.

\_\_\_\_\_ [1]

---

**THIS IS THE END OF THE QUESTION PAPER**

---

Examiner Only	
Marks	Remark
<input type="text"/>	<input type="text"/>



Permission to reproduce all copyright material has been applied for.  
In some cases, efforts to contact copyright holders may have been unsuccessful and CCEA  
will be happy to rectify any omissions of acknowledgement in future if notified.



*Rewarding Learning*

**General Certificate of Secondary Education  
2022**

---

# **Physics**

Unit 3A: Practical Skills

**Booklet A**

**Higher Tier**

**[GPY33]**

---

## **APPARATUS AND MATERIALS LIST AND CONFIDENTIAL INSTRUCTIONS**

**To be accessed by Head of Department only**

It is the responsibility of the centre to ensure that appropriate risk assessments are carried out for all practical skills assessments.

## Apparatus & Materials List

### Experiment 1 Density of a liquid

The list below shows the apparatus required per group.  
(A group may be up to 3 candidates.)

Measuring cylinder capable of measuring at least 50 cm<sup>3</sup>.

Small beaker capable of holding at least 250 cm<sup>3</sup> of water.

Large beaker capable of holding the supply of water.

Electronic balance to measure up to 500 g.

A supply of paper towels.

A small funnel and dropper may be provided if the centre feels it would be useful.

## Confidential Instructions

### Experiment 1 Density of a liquid

The apparatus should be set up prior to the group using it.

The measuring cylinder should be empty.

The small beaker should be empty at the start.

Ensure the electronic balance is set to measure to the nearest gram.

The container should have sufficient water to allow for spillage.

A supply of paper towels in the event of spillage.

It is not necessary for each group to have an electronic balance, these can be positioned so that groups can share.

A small funnel and dropper (optional).

## Apparatus & Materials List

### Experiment 2 The strength of an electromagnet

The list below shows the apparatus required per group.  
(A group may be up to 3 candidates.)

Power supply unit capable of delivering 1.5 A when connected to the 40-turn wire coil.

Ensure that the candidate does **NOT** have access to switch on the power supply.

Iron nail, of between 10 and 15 cm in length.

Insulated wire to wrap 40 turns on the nail and capable of carrying a current of 1.5 A without becoming hot.

Digital ammeter capable of reading at least 1.5 A without having to reset the scale.

5 connecting wires terminated with 4 mm plugs or crocodile clips.

Variable resistor suitable to adjust current from 0 to 1.5 A.

If using a rheostat the connection shown should be taped over (see diagram below).

Uncovered metal (steel) paper clips (about 40), each around 25 mm long (length not critical).  
These could be placed in a small beaker.

Sellotape or insulating tape.

Retort stand, boss head and clamp to hold the electromagnet.

G-clamp to hold the retort stand on the bench.

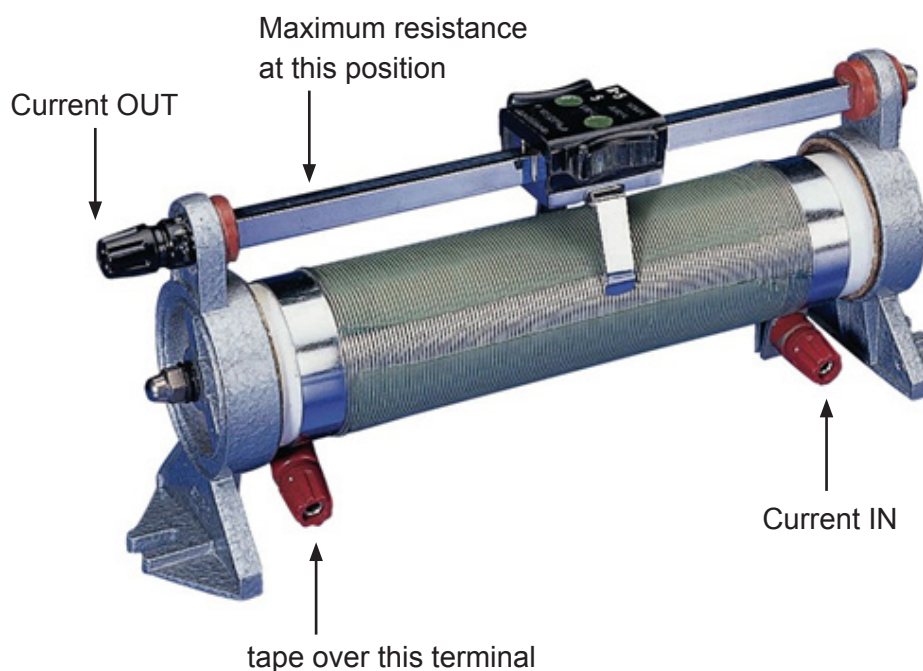

## Confidential Instructions

### Experiment 2 The strength of an electromagnet

For each candidate group, wrap about 40 turns of insulated copper wire around the iron nail. Use sellotape or insulating tape to ensure this coil does not unravel during the experiment.

The free ends of all wires should be terminated with 4 mm plugs or crocodile clips.

At each station clamp the coil vertically with the pointed end of the nail upwards using an iron stand, boss head and clamp. The flat end of the nail must be visible to the candidates.

Clamp the retort stand to the bench to prevent it toppling.

Place a small beaker containing 40 identical (steel) paper clips near the iron nail.

For each candidate group, construct the incomplete circuit as shown below.

Place the variable resistor alongside the incomplete circuit.

Ensure that the variable resistor is adjusted to give maximum resistance/lowest current.

